



ISA8000 Hardware Guide

Copyright Notice

This document is provided strictly as a guide. No guarantees can be provided or expected. This document contains the confidential information and/or proprietary property of Ivanti, Inc. and its affiliates (referred to collectively as "Ivanti") and may not be disclosed or copied without prior written consent of Ivanti.

Ivanti retains the right to make changes to this document or related product specifications and descriptions, at any time, without notice. Ivanti makes no warranty for the use of this document and assumes no responsibility for any errors that can appear in the document nor does it make a commitment to update the information contained herein. For the most current product information, please visit www.lvanti.com.

Copyright © 2023, Ivanti, Inc. All rights reserved.

Protected by patents, see <https://www.ivanti.com/patents>.

Contents

Revision History	5
Package Contents	6
System Overview	7
Introduction	7
LED Control Panel	7
Control Panel LEDs	8
Management Port LEDs	9
INT and EXT Port LEDs	10
Air Flow Estimate	10
Air Flow Direction	10
Beeping and Alarms	11
Hardware Specifications	12
System Measurements	12
Power Rating	12
Power Consumption	12
Environmental Requirements	15
Component Specifications	15
Where to Get Replacement Components	15
Console and Initial Configuration	16
Accessing ISA8000 Serial Console through Laptop	16
Accessing ISA8000 Console through Console Server	16
Powering On the System and Selecting the Personality	17
Configuring Basic Settings	18
Setting Up Ivanti Connect Secure Package / Ivanti Policy Secure Package	18
Change the Personality	19
Accessing the Web Admin Interface	21
Licensing the System	21
Installation	23
Preparing for Setup	23
Rack Mounting Instructions	25
Replacing the Power Supply Unit	27
Replacing the Hard Drive	28
Network Cables	36
Standard Warnings and Compliance	38
About Standard Warnings	38
Safety Certifications	38
Electrical Safety	38
General Safety	39
Installation Instructions	42
Circuit Breaker	43
Power Disconnection Warning	45
Equipment Installation	47
Restricted Area	49
Redundant Power Supplies	51

Backplane Voltage	53
Comply with Local and National Electrical Codes	55
Product Disposal	56
Power Cable and AC Adapter	58
Certification Statements	62

Revision History

The following table lists the revision history for this document:

Revision Number and Date	Description
1.3, August 2023	Updated "Console and Initial Configuration" section.
1.2, July 2023	Updated "Standard Warnings and Compliance" section.
1.1, July 2022	Added the following sections: <ul data-bbox="683 632 1117 737" style="list-style-type: none">• Replacing the Power Supply Unit• Replacing the Hard Drive Updated the following sections: <ul data-bbox="683 810 1365 915" style="list-style-type: none">• Powering On the System and Selecting the Personality• Configuring Basic Settings
1.0, January 2022	Initial Release

Package Contents

The ISA8000F/C package typically includes the following:

Item	Quantity
Rack Mount Rail Kit 1RU, ISA8000	1
Rail Screw Bag, ISA8000, Mounting Kit	1
Cable, Console, Gray, RJ45 to DB9, 6 ft.	1
Cable Generic, C13, 1 Power Cord	2
Cable, Power, C13/C14, 13A/125V, 1m	2
Packaging box, accessory kit, ISA	1
Quick Start Guide, ISA8000	1

System Overview

Introduction

The ISA8000 features a unique and highly optimized design for low wattage processor platforms. It is equipped with a high-efficiency low noise power supply. High-performance fans provide ample optimized cooling.

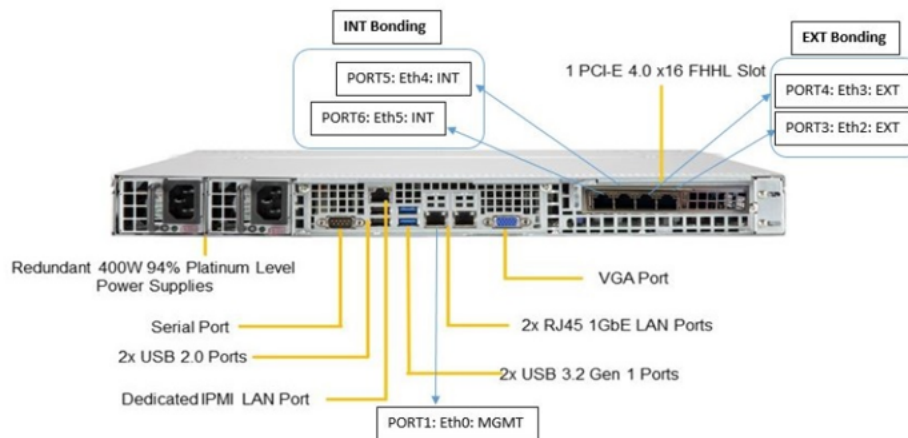

i For added system security, the USB ports have been disabled.

LED Control Panel

The control panel located on the front of the ISA8000 chassis includes power control buttons and status LEDs. This section describes the LED indicators and the appropriate responses.



Control Panel Buttons

The control panel includes a power on/off button and a reset button.



Power: The main power switch is used to apply or remove power from the power supply to the server system. Turning off system power with this button removes the main power but keeps standby power supplied to the system. Therefore, you must unplug system before servicing.



Reset: The reset button is used to reboot the system.

Control Panel LEDs

The control panel displays five LEDs to monitor the system.



Information LED: Alerts operator of several states, as noted in the table below:

Status	Description
Continuously on and red	An overheat condition has occurred. This may be caused by cable congestion.
Blinking red (1Hz)	Fan failure; check for an inoperative fan.
Blinking red (0.25Hz)	Power failure; check for a non-operational power supply.



NIC1 (GLAN1): Associated with the Management port. It indicates network activity when flashing.



NIC2 (GLAN2): Unused. Will always be off.



HDD: Indicates SATA drive activity when flashing.

- Continuously ON: indicates continuous read/write operation on HDD.
- Blinking: indicates Less activity on HDD.



Power: Indicates power is being supplied to the system power supply. This LED should be illuminated when the system is operating.

Management Port LEDs

The management port has two LEDs. The yellow LED indicates activity, while the link LED may be green, amber, or off to indicate the speed of the connection.

LED	Color	Description
Activity	Yellow (flashing)	Active
Link	Off	No connection
	Orange	1 Gbps speed
	Green	100 Mbps speed

INT and EXT Port LEDs

Two LAN ports are located on the NIC card. Each Ethernet port has two LEDs.

LED	Color	Description
Activity	Yellow (blinking)	LAN Active
Link	Off	10 Mbps link speed or no connection
	Orange	1 Gbps link speed
	Green	10 Gbps link speed

Air Flow Estimate

Equipped Cooling Fan and/or Active CPU Heat Sink	Estimated Overall System Air Flow Rate When All Four Cooling Fans Operated at Full Speed
Six Cooling FANS + 1 passive CPU Heat Sink	52 CFM

Air Flow Direction

The following table gives the air flow direction of the power supply fan and internal CPU fan.

Component	Air Flow Direction
Power Supply Fan	To the rear of the unit

Beeping and Alarms

Beep Code	Description
5 short beeps + 1 long beep every 5 seconds	No memory detected in the system
Continuous beep ("i" LED on front panel turns RED)	System overheat condition

Hardware Specifications

This chapter describes the specifications and components for ISA8000.

System Measurements

Below figures are for both unpackaged and packaged system.

Category	ISA8000c and ISA8000f	Shipping Box
Form factor	1U chassis	
Width	17.2" (437mm)	24" (609.6mm)
Height	1.7" (43mm)	8" (203.2mm)
Depth	19.98" (507mm)	26.5" (673.1mm)
Weight	Net Weight: 17.6 lbs (8 kg)	Net Weight: 24.2 lbs (11kg)

Power Rating

Below is the maximum power rating for the power supply:

Category	ISA8000c and ISA8000f
Power type	Single-phase
Input voltage range	100 - 240V
Input current	2.6 Amps maximum
Input wattage	400W
Input frequency range	50 – 60Hz

Power Consumption

A power consumption estimate is usually around 15% to 20% higher than the actual power measurement. The user's system power consumption may vary based on the workload and environment.



This power consumption data mentioned in the tables below is worst-case scenario and is meant for reference only

ISA8000c

Devices	Max Pwr(W)	Actual Pwr(W)	+12V current (A)	+5V current (A)	+3.3V current (A)	+5VSB current (A)	-12V current (A)
Motherboard:							
Motherboard	46.6	46.6	3.9				
Processor	150.0	150.0	12.5				
Memory	9.0	9.0	0.8				
PCIe3 RJ45 Adapter	18.0	18.0	1.5				
Trusted Platform Module (TPM)	2.5	2.5		0.5			
USB Peripherals (Generic)	2.5	2.5		0.5			
Motherboard Total:	228.6	228.6	18.6	1.0			
Fans (Qty 6):	75.6	75.6	6.3				
Storage Drives:	25.5	25.5	1.4	1.8			
Total Current			26.3	2.8			
Total Power	329.7 W (1124.9 BTU/h)	329.7 W (1124.9 BTU/h)					

ISA8000f

Devices	Max Pwr(W)	Actual Pwr(W)	+12V current (A)	+5V current (A)	+3.3V current (A)	+5VSB current (A)	-12V current (A)
Motherboard:							
Motherboard	46.6	46.6	3.9				
Processor	150.0	150.0	12.5				
Memory	9.0	9.0	0.8				
PCIe3 RJ45 Adapter	8.0	8.0	0.7				
Trusted Platform Module (TPM)	2.5	2.5		0.5			
USB Peripherals (Generic)	2.5	2.5		0.5			
Motherboard Total:	218.5	218.5	17.8	1.0			
Fans (Qty 6):	75.6	75.6	6.3				
Storage Drives:	25.5	25.5	1.4	1.8			
Total Current			23.4	2.8			
Total Power	319.6 W (1019.5 BTU/h)	319.6 W (1019.5 BTU/h)					

Environmental Requirements

Category	ISA8000c and ISA8000f
Operating temperature	10°C - 35°C (50°F - 95°F)
Non-operating temperature	-40°C to 70°C (-40°F to 158°F)
Operating Relative humidity	8% to 90% (non-condensing)
Non-operating Relative humidity	5% to 95% (non-condensing)

Component Specifications

Category	ISA8000c and ISA8000f
CPU	Intel Xeon Gold 5317 (x86) on the Ivanti ISA8000c Intel Xeon Gold 5317 (x86) on the Ivanti ISA8000f
Memory	Two 32GB DDR4
Storage HDD	Two 3.5"2TB SATA 6Gb/s,7.2KRPM, 256MB,512N
Storage SSD	SSD, 480G SATA
Network ports	Copper, Std LP 4-port 10G RJ45 (ISA8000C) Fiber, Std LP 4-port 10G SFP+ (ISA8000F) One RJ45 1GbE LAN port
Cooling	Six 40x40x28 mm Fan(s)

Where to Get Replacement Components

Although not frequently, you may need replacement parts for your system. To ensure the highest level of professional service and technical support, go to [Support Center](#).

Console and Initial Configuration

Accessing ISA8000 Serial Console through Laptop

1. Get the USB-to-DB9 (female) cable (this cable is not provided by Ivanti).



2. Connect the USB port to the laptop and serial DB9 female port to the ISA8000 console.
3. Configure a terminal emulation utility running on the laptop, such as HyperTerminal or PuTTY, to use these serial connection parameters: 9600 bits per second, 8-bit no parity (8N1), 1 stop bit, no flow control.
4. Connect a network cable from the INT port (internal port) on the appliance to a switch port.



To find your COM port in Windows, go to Start > Search > Device Manager > Ports (COM & LPT) > USB Serial Port (COM#).

Accessing ISA8000 Console through Console Server

1. Get the RJ45-to-DB9 serial cable.



2. Connect the RJ45 port in RJ45-to-DB9 serial cable to the console server and serial DB9 female to the ISA8000 console (DB9 male).

3. Configure a terminal emulation utility running on the laptop, such as HyperTerminal or PuTTY, connect using telnet to the console server IP and the port number it is connected to.
4. Connect a network cable from the INT port (internal port) on the appliance to a switch port.

Powering On the System and Selecting the Personality

Do this:

1. Connect the AC power cord from the power supply to a power source.
2. Press the power switch on the front of the system.
3. Observe the status LEDs (where applicable) on each power supply faceplate. If an AC power supply is correctly installed and functioning normally, the AC OK and DC OK LEDs light steadily, and the PS FAIL LED is not lit.



After powering off a power supply, wait at least 60 seconds before turning it back on. After powering on a power supply, wait at least 60 seconds before turning it off.

After the power supply is powered on, it can take up to 60 seconds for status indicators—such as the status LEDs on the power supply and the show chassis command display—to indicate that the power supply is functioning normally. Ignore error indicators that appear during the first 60 seconds.

4. The device reboots, and you see the GRUB boot menu. Choose the Factory Reset option using the down-arrow key which supports to select the personality. Please note that here timeout is 3 seconds. If the selection is not made within this period, then the device boots up to current image.

```
GNU GRUB version 2.04
*****
* Current
* Factory Reset
*
*
*
*
*
*
*
*
*
*
*
*
*
*
*****
Use the * and * keys to select which entry is highlighted.
Press enter to boot the selected OS, `e' to edit the commands
before booting or `c' for a command-line.
```



In case the user fails to select the Factory Reset option, then system will boot up with current image. Then user needs to power cycle the device, and select the Factory Reset option and follow with the above procedure.

Configuring Basic Settings

When you bring up a new ISA8000 for the first time, you need to enter basic network and machine information through the console to make it accessible to the network. After entering these settings, you can continue configuring the ISA8000 through the administrator Web console.

The installation process may take up to 30 minutes.

Do this to perform basic setup:

1. In Serial com console, check that the image loaded from local disk. i.e., current partition.
2. Enter the number corresponding to the personality for which you want to configure ISA8000.

```
Starting Factory Reset...
Please choose from among the following options:
[1] Ivanti Connect Secure NN.N-R1 (Build NNN)
[2] Ivanti Policy Secure NN.N-R1 (Build NNN)
Choice: █
```

3. Enter **y** to select the appliance as a stand-alone node.

```
Registration Status : 4 Internal Port Status : 0
Configuring Networking.

Welcome to the basic configuration of your appliance!

You must configure your appliance as a stand-alone node or as a member of a clustered configuration.
Will this appliance be a stand-alone node? (y/n)? █
```

Setting Up Ivanti Connect Secure Package / Ivanti Policy Secure Package

To set up [1] Ivanti Connect Secure package or [2] Ivanti Policy Secure package, do the following:

1. Enter **y** to accept the license terms (or enter **r** to read the license first).

2. Follow the directions in the console, and enter the machine information for which you are prompted, including the following:
 - Internal port IP address (you configure the external port through the administrator Web console after initial configuration)
 - Internal port network mask
 - Internal port default gateway address
 - Internal port default VLAN (optional)
 - Primary DNS server address
 - Admin username
 - Admin password
 - REST API access (for this administrator)
 - Digital certificate
 - Common name (example: secure.company.com)
 - Organization name (example: Company Inc.)
 - Register Ivanti Connect Secure with Ivanti Neurons for Secure Access

After you perform the basic setup, you are ready to license the software, verify accessibility, and complete the configuration process through the ISA8000 administrator Web console.

Change the Personality

If ISA8000 is set up as Ivanti Connect Secure or Ivanti Policy Secure device, it can be switched to any other personality anytime. Changing a personality deletes all configuration files and system and user data. You must perform the basic setup again to reestablish network connectivity. The installation process may take up to 20 minutes.

To change the personality:

1. Start a console session and in the options prompt, enter **4** to select System Operations.

```

Current version: 22.1R1 (build 393)
Reset version: 22.1R1 (build 393) Ivanti Connect Secure
                22.1R1 (build 201) Ivanti Policy Secure

Licensing Hardware ID: 0481MBPGE0YW90PPS
Serial Number: 0481032015100020

Please choose from among the following options:
 1. Network Settings and Tools
 2. Create admin username and password
 3. Display log/status
 4. System Operations
 5. Toggle password protection for the console (Off)
 6. Create a Super Admin session
 7. System Maintenance
 8. Reset allowed encryption strength for SSL
Choice: 1
    
```

2. In the operation to perform, enter **1** to select Reboot this <Ivanti Connect Secure/Ivanti Policy Secure>.

```

Please choose the operation to perform:
 1. Reboot this Ivanti Connect Secure
 2. Shutdown this Ivanti Connect Secure
 3. Restart services at this Ivanti Connect Secure
 4. Rollback this Ivanti Connect Secure
 5. Factory reset this Ivanti Connect Secure
 6. Clear all configuration data at this Ivanti Connect Secure
 7. Install self-signed certificate
21. Clear all session data at this Ivanti Connect Secure
22. Clear all Named Users at this Ivanti Connect Secure
24. Clear behavioral analytics database
93. Toggle resource throttling (Enabled)
94. Clear custom HTTP headers
<return to go back to main menu>
Choice: 1
    
```

3. After system reboot, choose **Factory Reset** option.

```

GNU GRUB version 2.04

*****
* Current
*Factory Reset
*
*
*
*
*
*
*
*
*
*
*
*****

Use the * and * keys to select which entry is highlighted.
Press enter to boot the selected OS, 'e' to edit the commands
before booting or 'c' for a command-line.
    
```

4. In the personality selection, choose the personality you want to change to and follow the instructions to complete the configuration.

```
Starting Factory Reset...
Please choose from among the following options:
[1] Ivanti Connect Secure NN.N.R1 (Build NNN)
[2] Ivanti Policy Secure NN.N.R1 (Build NNN)
Choice: █
```

Accessing the Web Admin Interface

1. Launch a web browser from a laptop that is network connected.
2. Point the browser at the same IP address that was assigned to the internal port followed by /admin (for example, https://a.b.c.d/admin).

With base image version 22.1R4, admin portal access might fail using internal port. Please follow the below instructions instead if you encounter the issue:

1. Enable the management port and assign an IP address to it.
2. Log in to the admin UI via the management port IP.
3. Upgrade to any latest release. After upgrading to the latest release, admin portal can be accessed via internal port.
3. When prompted with the security alert to proceed without a signed certificate, click **Yes**. When the administrator sign-in page appears, you have successfully connected your device to the network.
4. On the sign-in page, enter the administrator username and password you created earlier. Then click Sign In. The administrator Web console opens to the Overview page.

Licensing the System

After you install the device and perform basic setup, you are ready to license it.

To license your device, follow instructions received in an email from Ivanti. For more information, contact [Support Center](#).

The device uses the common machine and organization names to create a self-signed digital certificate for use during product evaluation and initial setup.

We strongly recommend that you import a signed digital certificate from a trusted certificate authority (CA) before you deploy the device for production use.

Installation

This chapter provides instructions and tips for installing the chassis into a rack.

Preparing for Setup

Please read this section in its entirety before beginning the installation procedure.

Choosing a Setup Location

Decide on a suitable location for the rack. It should be a clean, dust-free area that is well ventilated. Avoid areas where heat, electrical noise and electromagnetic fields are generated. Place it near a grounded power outlet.

- Leave at least 25 inches clearance in front of the rack to open the front door completely.
- Leave approximately 30 inches of clearance in the back of the rack to allow for sufficient airflow and ease in servicing.
- Install in a restricted access location, such as a dedicated equipment room or service closet.

Ambient Operating Temperature

If installed in a closed or multi-unit rack assembly, the ambient operating temperature of the rack environment may be greater than the ambient temperature of the room. Install the equipment in an environment compatible with the manufacturer's maximum rated ambient temperature (TMRA).

Adequate Airflow

Equipment should be mounted into a rack so that the amount of airflow required for safe operation is not compromised.

Circuit Overloading

Avoid overloading the power supply circuitry or any overcurrent protection equipment. Use equipment nameplate ratings to calculate your requirements.

Reliable Ground

A reliable ground must be maintained at all times. To ensure this, ground the rack, itself. Pay attention to power supply connections other than the direct connections to the branch circuit, such as power strips.

Physical Rack Precautions

- Ensure that the leveling jacks on the bottom of the rack are fully extended to the floor with the full weight of the rack resting on them.
- In single rack installation, stabilizers should be attached to the rack.
- In multiple rack installations, the racks should be coupled together.
- When mounting this unit in a partially filled rack, load the rack from the bottom to the top with the heaviest component at the bottom of the rack. If this is the only unit in the rack, mount it at the bottom.
- Always make sure the rack is stable before extending a component from the rack. Extend only one component at a time. Extending two or more simultaneously may cause the rack to become unstable.

Warning: Follow these guidelines to prevent injury. Take all precautions to ensure the system remains stable

General Server Precautions

- Review the electrical and general safety precautions that came with the components you are adding to your chassis.
- Determine the placement of each component in the rack.
- Install the heaviest server components on the bottom of the rack first, and then work up.
- Use a regulating, uninterruptible power supply (UPS) to protect the server from power surges, voltage spikes and to keep your system operating in case of a power failure.
- Allow the hard drives and power supply modules to cool before touching them.
- Always keep the rack front door, all panels and all components on the servers closed when not servicing, to maintain proper cooling.

Warning: If you unscrew and open the chassis cover, it will void your product warranty.

Rack Mounting Instructions

The chassis can be mounted in a rack for secure storage and use. To set up your rack, follow the step-by-step instructions included in this manual.

Rail packaging includes:

- One pair of inner slides to be installed on the chassis.
- One pair of outer slides to be installed in the rack.
- Two pairs of short brackets to be used on the front side of the outer slides.



One pair of short brackets include screw threads, and the other pair do not. Use the only pair that will fit into your rack.

- One pair of long brackets to be used on the rear side of the outer slides.

Installing Inner Slides

1. Locate the right inner slide, (-the slide that will be used on the right side of chassis when facing the front panel of the chassis).
2. Align the four(4) square holes on the right inner slide against the hooks on the right side of the chassis as shown in the illustration below.
3. Securely attach the slide to the chassis with two M4 flat head screws and repeat the steps 1-3 to install the left inner slide to the left side of the chassis.

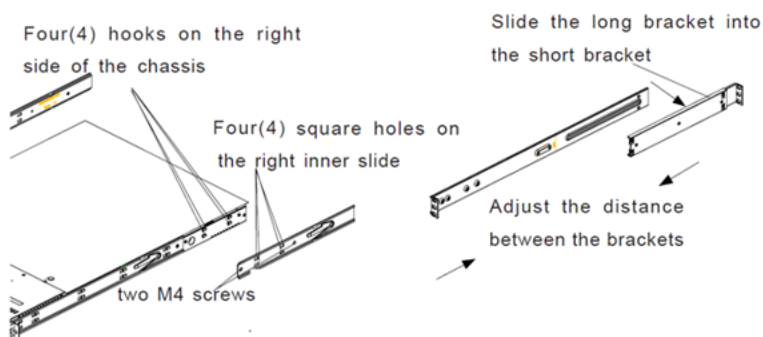

Installing Outer Slides

1. Measure the distance from the front rail of the rack to the rear rail of the rack.

2. Attach a short bracket to the rear side of the right outer slide, and a long bracket to the front side of the right outer slide as shown above on the right.
3. Adjust the short and long brackets to the proper distance so that the chassis can snugly fit into the rack.
4. Secure the slides to the cabinet with screws. Repeat steps 1-4 for the left outer slide.

Installing the Slide Assemblies to the Rack

1. After you have installed the short and long brackets to the outer slides, you are ready to install the whole slide assemblies (outer slides with short and long brackets attached) to the rack. (See the previous page.)
2. Use M5 screws and washers to secure the slide assemblies into the rack as shown in the illustration below.

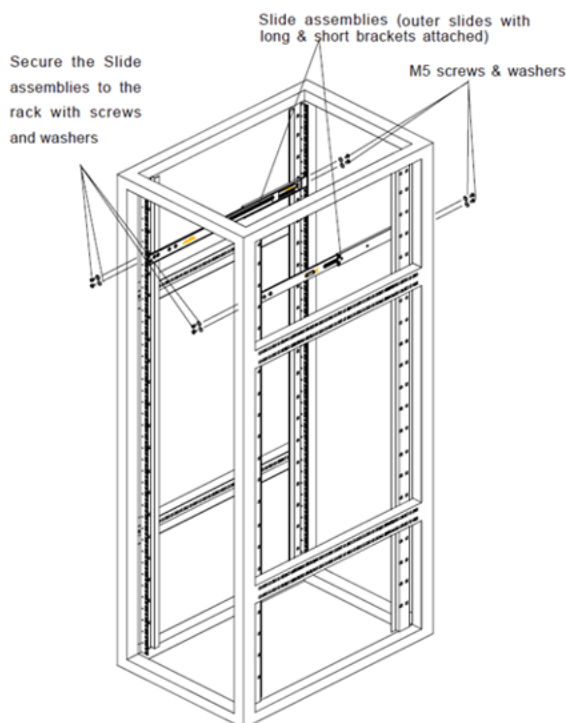

Installing the Chassis into the Rack

1. Push the inner slides, which are attached to the chassis, into the grooves of the outer slide assemblies that are installed in the rack as shown in the illustration below:

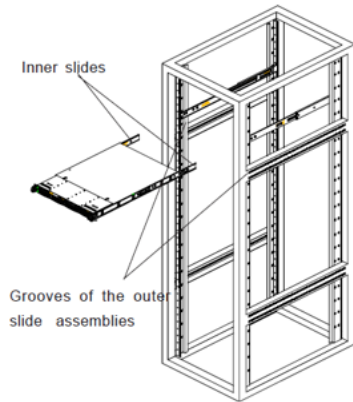

2. Push the chassis all the way to the back of the outer slide assemblies as shown in the illustration below. (The plastic bezel is not included in the package.)

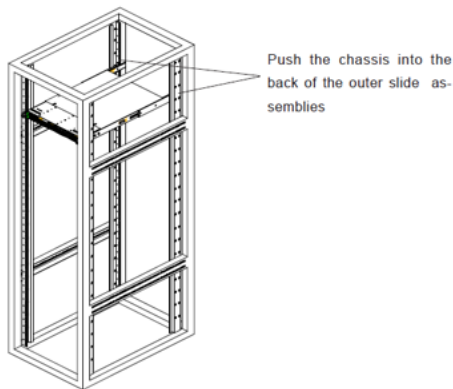

Replacing the Power Supply Unit

The ISA8000 chassis has two 400W power supplies. This power supply is auto-switching capable. This enables it to automatically sense and operate at a 100V to 240V input voltage. An amber light will be illuminated on the power supply when the power is off. An illuminated green light indicates that the power supply is operating.

The ISA8000 chassis includes a redundant power supply. It is not necessary to power down the server to replace a power supply. PWR1 and PWR2 are shown in the graphic below:



To replace the power supply:

1. Push the Release tab (on the back of the power supply) as illustrated.
2. Pull the power supply out using the handle provided.
3. Replace the failed power module with a new unit. To do this, push the new power supply module into the power bay until you hear a click.
4. Plug the AC power cord back into the module.

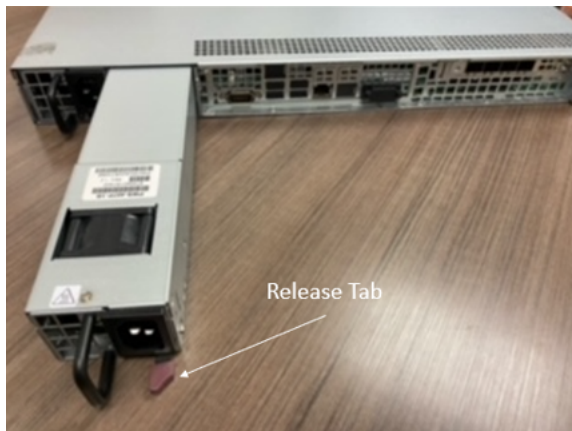

Warning: Removal of two power supply units at the same time is not recommended.

Replacing the Hard Drive

The ISA8000 chassis has two replaceable hard disk drives located in slot #2 and slot #3.

Note: The SSD drive in slot 1 is not replaceable and should never be removed.



You can check the HDD and RAID status from the Maintenance page of ICS Gateway Admin UI. If the status of HDD1 or HDD2 displays "Missing" or "Faulty", then that specific HDD needs to be replaced. If any one of the two HDDs has gone bad, then the RAID will not function.

The screenshot shows the Maintenance page of the ICS Gateway Admin UI. The navigation bar includes System, Authentication, Administrators, Users, and Maintenance. A "Test Connectivity" button is visible. Under "Hardware Status", the "Hard Disk Status" section indicates "Hard Disk RAID is in Single Drive Mode". A table shows the status of two HDDs: HDD 1 is "Missing" and HDD 2 is "Active". The "Fan Status" section shows four fans, all with green status indicators. At the bottom, "Power Supply" is operational and "Temperature" is 43 °C.

Disk	Status
HDD 1	Missing
HDD 2	Active

Fan	Status
1	●
2	●
3	●
4	●

Power Supply: Installed power supply/supplies are operational
Temperature: 43 °C

From 22.1R4 release, hot swapping of hard drive is supported. When you are replacing the hard drive during Maintenance period, and shutting down the server does not affect your network, follow the cold swap procedure. Otherwise, follow the hot swap procedure.

Replacing Faulty Hard drive (Cold Swap)

To replace a hard drive (cold swap):

1. Power off the system.
2. Push the Release button of the faulty hard drive to release the ejector lever.



3. Pull the Release lever on the drive that needs to be replaced as shown below.



4. Pull the hard drive out using the lever provided. This will disengage the HDD connector from the HDD controller backplane.



5. Replace the failed hard drive with a new unit. To do this, push the new hard drive into the HDD bay and snap the lever shut.
6. Power on the system and continuously press the Del button to enter the BIOS settings.
7. Select Advanced > PCH SATA Configuration.

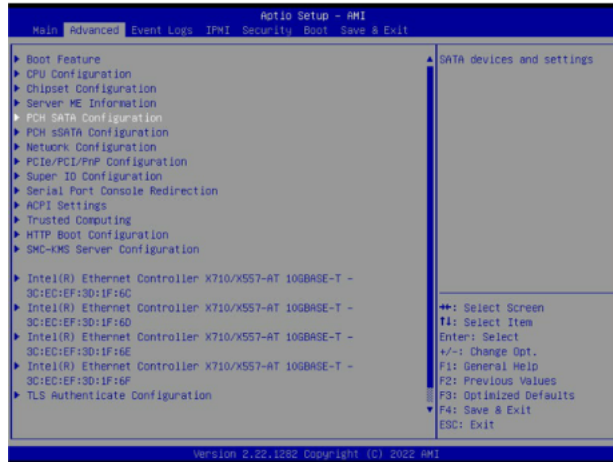

8. Check for the status of the newly inserted HDD.

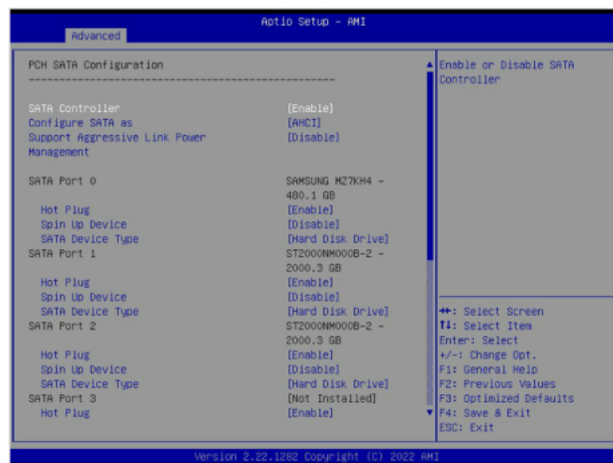

9. Once the new HDD is detected, reboot the system.
10. When system boots up properly, check for the HDD and RAID status.
11. Log in to the ICS Gateway Admin UI and select the Maintenance tab. The message "RAID Recovery in progress" will be displayed.

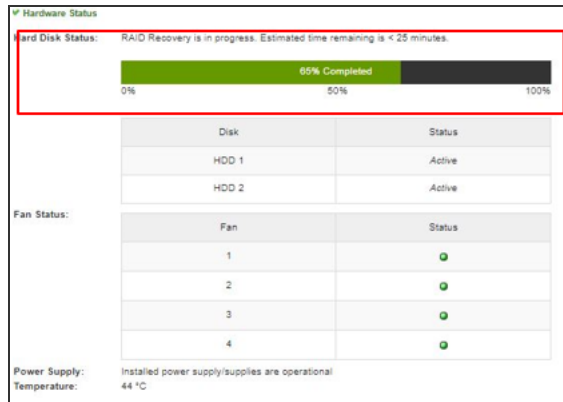

- The process will take 30-45 mins.
- Once the process is completed, HDD and RAID display the status "HDD Active" and "Hard Disk Raid is Operational".

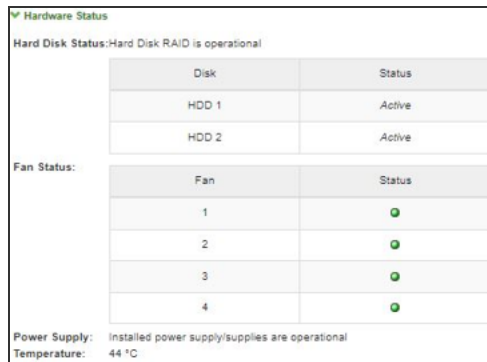

Warning: Once RAID is in the Active state, only one HDD replacement is allowed.

Replacing Faulty Hard drive (Hot Swap)

To replace a hard drive (hotswap):

- Telnet to the admin console.
- Select option 4. System Operations from the CLI menu.

```

Please choose from among the following options:
 1. Network Settings and Tools
 2. Create admin username and password
 3. Display log/status
 4. System Operations
 5. Toggle password protection for the console (Off)
 6. Create a Super Admin session
 7. System Maintenance
 8. Reset allowed encryption strength for SSL
Choice: 4

```

- Then select option 20. Manage RAID that provides RAID management menu options.

```
Please choose the operation to perform:
 1. Reboot this Ivanti Connect Secure
 2. Shutdown this Ivanti Connect Secure
 3. Restart services at this Ivanti Connect Secure
 4. Rollback this Ivanti Connect Secure
 5. Factory reset this Ivanti Connect Secure
 6. Clear all configuration data at this Ivanti Connect Secure
 7. Install self-signed certificate
20. Manage RAID
21. Clear all session data at this Ivanti Connect Secure
22. Clear all Named Users at this Ivanti Connect Secure
24. Clear behavioral analytics database
93. Toggle resource throttling (Enabled)
94. Clear custom HTTP headers
<return to go back to main menu>
Choice: 20

Are you sure you want to manage RAID? (y/n) y
```

- Select option 5. Check RAID status.

```
Please choose from among the following options:
 1. Remove Disk1
 2. Remove Disk2
 3. Add Disk1
 4. Add Disk2
5. Check RAID status
<return to go back to main menu>
Choice: 5
```

- When both the disks are active and working, the status shows Up.

```
partition      disk 1      disk 2
md1 :          Up          Up
md2 :          Up          Up
md3 :          Up          Up
md5 :          Up          Up
md6 :          Up          Up
md7 :          Up          Up
md8 :          Up          Up
md9 :          Up          Up
md10 :         Up          Up
md11 :         Up          Up
md12 :         Up          Up
md13 :         Up          Up
```

- Return to the RAID management menu, and select the faulty disk that you want to remove, for example, option 1. Remove Disk1.

```
Please choose from among the following options:
1. Remove Disk1
2. Remove Disk2
3. Add Disk1
4. Add Disk2
5. Check RAID status
<return to go back to main menu>
Choice: 1
```

7. Select option 5. Check RAID status. The status of disk1 shows Down.

```
partition    disk 1      disk 2
md1 :        Down      Up
md2 :        Down      Up
md3 :        Down      Up
md5 :        Down      Up
md6 :        Down      Up
md7 :        Down      Up
md8 :        Down      Up
md9 :        Down      Up
md10 :       Down      Up
md11 :       Down      Up
md12 :       Down      Up
md13 :       Down      Up
```

Now you can physically replace faulty disk1 with new working disk.

8. Identify the slot where faulty disk1 is located. Push the Release button to release the ejector lever.



9. Pull the Release lever of faulty disk1 as shown below.



10. Pull the hard drive out using the lever provided. This will disengage the HDD connector from the HDD controller backplane.



11. Replace the faulty disk1 with a new unit. To do this, push the new hard drive into the HDD bay and snap the lever shut.
12. In the RAID management menu, select 3. Add Disk1.

```

Please choose from among the following options:
1. Remove Disk1
2. Remove Disk2
3. Add Disk1
4. Add Disk2
5. Check RAID status
<return to go back to main menu>
Choice: █

```

13. Log in to the ICS Gateway Admin UI and select the Maintenance tab. The message "RAID Recovery in progress" will be displayed.

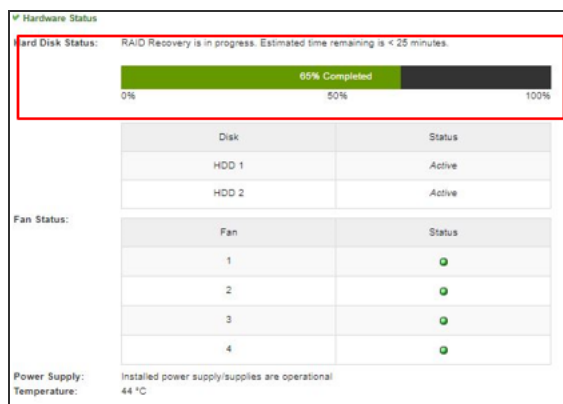

14. The process will take 30-45 mins.
15. Once the process is completed, HDD and RAID display the status "HDD Active" and "Hard Disk Raid is Operational".

Hardware Status	
Hard Disk Status: Hard Disk RAID is operational	
Disk	Status
HDD 1	Active
HDD 2	Active
Fan Status:	
Fan	Status
1	●
2	●
3	●
4	●
Power Supply: Installed power supply/supplies are operational	
Temperature: 44 °C	

Warning: Once RAID is in the Active state, only one HDD replacement is allowed.

Network Cables

The ISA8000f model offers SFP+ interfaces supporting 10G fiber networks.

ISA8000f

This appliance offers dual and redundant 10G network interface ports (4 ports total) in the SFP+ form factor. Ivanti has qualified SFP+/Cable combinations (Short Range, 850 nm) and offers them for sale as an optional accessory. Check the Price book for the SKUs.

Customers can either purchase this option from Ivanti or procure it from their vendor of choice. Contact your Solutions Engineer or Technical Support for additional information and Technical Specifications.



The performance tests done with Finisar (Juniper) transceiver on the cable end that is connected to the Juniper switch, and Avago transceiver on the cable end that is connected to the ISA8000 show no impact on the throughput using longer cables. The maximum cable length qualified is 15 meters.

Support for 1G Network:

- The Network interface card in the ISA8000f is designed for 10G networks, but it can support 1G networks when used with 1G transceivers at both ends of the network. No manual set up is required. Ivanti does not offer any optional 1G transceiver / cable as an option for sale. Any supplier's short range 1G transceiver should work.
- <https://www.broadcom.com/products/fiber-optic-modules-components/networking/electrical-transceiver/abcu-5741rz>

The ISA8000f model offers SFP+ interfaces supporting 10G fiber networks.

10G fiber solution supports either an Avago SFP+ direct attached 3 meters transceiver cable (ISA-SFP-10GE-SR-3M), the Avago SFP+ detached transceiver with 5 meters fiber cable (ISA-SFP-10GE-SR-DE), or any of the SFP+ fiber transceivers listed below using from 5 meters to 25 meters cable.

Listed below are the supported detached 10Gb/s SFP+ fiber transceivers:

- Avago AFBR-709DMZ
- Cisco SFP-10G-SR-S Module (S-Class)
- Cisco SFP-10G-SR Module
- Juniper EX-SFP-10GE-SR
- HP X132 10G SFP+ LC SR

ISA8000c

This appliance offers dual and redundant 10G network interface ports (4 ports total) in the RJ45 form factor compatible with category 6 or 6A network cables.

The hardware supports auto-negotiation between 1G and 10G networks over an RJ45 connection. Ivanti does not offer any RJ45 cables/accessories as an optional SKU.

Standard Warnings and Compliance

About Standard Warnings

The following statements are industry standard warnings, provided to warn the user of situations that have the potential for bodily injury. Should you have questions or experience difficulty, contact Ivanti's Technical Support department for assistance. Only certified technicians should attempt to install or configure components.

Safety Certifications

- USA - UL
- Canada - UL
- Europe/CE Mark
- EN 62368/IEC 62368-Compliant
- CCC Exemption

Electrical Safety

Basic electrical safety precautions should be followed to protect yourself from harm and the system from damage:

- Be aware of the locations of the power on/off switch on the system, as well as the room's emergency power-off switch, disconnection switch, or electrical outlet. If an electrical accident occurs, you can quickly remove power from the system.
- Do not work alone when working with high voltage components.
- Power should always be disconnected from the system when removing or installing system components. When disconnecting power, you should first power down the system with the operating system and then unplug the power cords from all the power supply modules in the system.
- When working around exposed electrical circuits, another person who is familiar with the power-off controls should be nearby to switch off the power, if necessary.

- Use only one hand when working with powered-on electrical equipment. This is to avoid making a complete circuit, which will cause electrical shock. Use extreme caution when using metal tools, which can easily damage any electrical components they come into contact with.
- Do not use mats designed to decrease electrostatic discharge as protection from electrical shock. Instead, use rubber mats that have been specifically designed as electrical insulators.
- The power supply power cord must include a grounding plug and must be plugged into grounded electrical outlets.
- Use a grounded wrist strap designed to prevent static discharge.

General Safety

- Keep the area around the system clean and free of clutter.
- While working on the system, do not wear loose clothing such as neckties and unbuttoned shirt sleeves, which can come into contact with electrical circuits or be pulled into a fan.
- Remove any jewelry or metal objects from your body, which are excellent metal conductors that can create short circuits and harm you if they come into contact with areas where power is present.



Warning!

This warning symbol means danger. You are in a situation that could cause bodily injury. Before you work on any equipment, be aware of the hazards involved with electrical circuitry and be familiar with standard practices for preventing accidents.

警告の定義 この警告サインは危険を意味します

。

人身事故につながる可能性がありますので、いずれの機器でも動作させる前に、

電気回路に含まれる危険性に注意して、標準的な事故防止策に精通して下さい。

此警告符号代表危険。

您正处于可能受到严重危害的工作环境中。在您使用任何设备开始工作之前，务必充分意识到触电的危险，并熟练掌握防止事故发生的准备工作程序。请根据每次警告末尾的声明号码找到此处的安全性警告说明的翻译文本。

此警告符號代表危險。

您正處於可能身體可能會受損傷的工作環境中。在您使用任何設備之前，請注意觸電的危險，並且要熟悉預防事故發生的標準工作程序。請

依照每一注意事項後的號碼找到相關的翻譯說明內容。

Warnung

WICHTIGE SICHERHEITSHINWEISE

Dieses Warnsymbol bedeutet Gefahr. Sie befinden sich in einer Situation, die zu Verletzungen führen kann. Machen Sie sich vor der Arbeit mit Geräten mit den Gefahren elektrischer Schaltungen und den üblichen Verfahren zur Vorbeugung vor Unfällen vertraut. Suchen Sie mit der am Ende jeder Warnung angegebenen Anweisungsnummer nach der jeweiligen Übersetzung in den übersetzten Sicherheitshinweisen, die zusammen mit diesem Gerät ausgeliefert wurden.

BEWAHREN SIE DIESE HINWEISE GUT AUF.

INSTRUCCIONES IMPORTANTES DE SEGURIDAD

Este símbolo de aviso indica peligro. Existe riesgo para su integridad física. Antes de manipular cualquier equipo, considere los riesgos de la corriente eléctrica y familiarícese con los procedimientos estándar de prevención de accidentes. Al final de cada advertencia encontrará el número que le ayudará a encontrar el texto traducido en el apartado de traducciones que acompaña a este dispositivo.

GUARDE ESTAS INSTRUCCIONES.

IMPORTANTES INFORMATIONS DE SÉCURITÉ

Ce symbole d'avertissement indique un danger. Vous vous trouvez dans une situation pouvant entraîner des blessures ou des dommages corporels. Avant de travailler sur un équipement, soyez conscient des dangers liés aux circuits électriques et familiarisez-vous avec les procédures couramment utilisées pour éviter les accidents. Pour prendre connaissance des traductions des avertissements figurant dans les consignes de sécurité traduites qui accompagnent cet appareil, référez-vous au numéro de l'instruction situé à la fin de chaque avertissement.

CONSERVEZ CES INFORMATIONS.

תקנון הצהרות אזהרה

הצהרות הבאות הן אזהרות על פי תקני התעשייה, על מנת להזהיר את המשתמש מפני חבלה פיזית אפשרית. במידה ויש שאלות או היתקלות בבעיה כלשהי, יש ליצור קשר עם מחלקת תמיכה

טכנית של סופרמיקרו. טכנאים מוסמכים בלבד רשאים להתקין או להגדיר את הרכיבים.

יש לקרוא את הנספח במלואו לפני התקנת או הגדרת הרכיבים במארזי סופרמיקרו.

تحذّر! هذا الزهزّع خطر أك ف حالة وكي أي تتسبب ف إصابة جسدة . تعول على أي هعدات، كي على علن بالوخطز الأوجة عي الذوائز قبل أي

الكهزبائة وكي على دراة بالووارسات البقاية لوع وقنع أي حادث استخدم رقن الپای الوصص ف هاة كل تحذّر للعتنر تزجوتها

안전을 위한 주의사항 경고!

이 경고 기호는 위험이 있음을 알려 줍니다. 작업자의 신체에 부상을 야기 할 수 있는 상태에 있게 됩니다. 모든 장비에 대한 작업을 수행하기 전에 전기회로와 관련된 위험요소들을 확인하시고 사전에 사고를 방지할 수 있도록 표준 작업절차를 준수해 주시기 바랍니다.

해당 번역문을 찾기 위해 각 경고의 마지막 부분에 제공된 경고문 번호를 참조하십시오

BELANGRIJKE VEILIGHEIDSINSTRUCTIES

Dit waarschuwings symbool betekent gevaar. U verkeert in een situatie die lichamelijk letsel kan veroorzaken. Voordat u aan enige apparatuur gaat werken, dient u zich bewust te zijn van de bij een elektrische installatie betrokken risico's en dient u op de hoogte te zijn van de standaard procedures om ongelukken te voorkomen. Gebruik de nummers aan het eind van elke waarschuwing om deze te herleiden naar de desbetreffende locatie.

BEWAAR DEZE INSTRUCTIES

Installation Instructions



Warning!

Read the installation instructions before connecting the system to the power source.

設置手順書 システムを電源に接続する前に、設置手順書をお読み下さい。

警告

将此系接源前,先安明。

警告 將系統與電源連接前,請先閱讀安裝說明。

Warnung

Vor dem Anschließen des Systems an die Stromquelle die Installationsanweisungen lesen.

¡Advertencia!

Lea las instrucciones de instalación antes de conectar el sistema a la red de alimentación.

Attention

Avant de brancher le système sur la source d'alimentation, consulter les directives d'installation.

יש לקרוא את הוראות התקנה לפני חיבור המערכת למקור מתח.

اقر إرشادات التركيب قبل توصيل النظام إلى مصدر للطاقة

시스템을 전원에 연결하기 전에 설치 안내를 읽어주십시오.

Waarschuwing

Raadpleeg de installatie-instructies voordat u het systeem op de voedingsbron aansluit.

Circuit Breaker



Warning!

This product relies on the building's installation for short-circuit (overcurrent) protection. Ensure that the protective device is rated not greater than: 250 V, 20 A.

サーキット・ブレーカー この製品は、短絡(過電流)保護装置がある建物での設置を前提としています。保護装置の定格が250 V、20 Aを超えないことを確認下さい。

警告

此品的短路(过 流)保 由建筑物的供系 提供,确保短路保 的 定流不大于250V,20A。

警告 此產品的短路(過載電流)保護由建築物的供電系統提供,確保短路保護設備的額定電流不大於250V,20A。

Warnung

Dieses Produkt ist darauf angewiesen, dass im Gebäude ein Kurzschluss- bzw. Überstromschutz installiert ist. Stellen Sie sicher, dass der Nennwert der Schutzvorrichtung nicht mehr als: 250 V, 20 A beträgt.

¡Advertencia!

Este equipo utiliza el sistema de protección contra cortocircuitos (o sobrecorrientes) del edificio. Asegúrese de que el dispositivo de protección no sea superior a: 250 V, 20 A.

Attention

מוצר זה מסתמך על הגנה המותקנת במבנים למניעת קצר חשמלי. יש לוודא כי

המכשיר המגן מפני הקצר החשמלי הוא לא יותר מ 250 V, 20 A-המכשיר המגן מפני הקצר החשמלי הוא לא יותר מ

هذا المنتج يعتمد على معدات الحماية مه الدوائر القصيرة التي تم تثبيتها في

المبنى

250V 20A, تأكد من أن تقييم الجهاز الوقائي ليس أكثر من:

경고!

이 제품은 전원의 단락(과전류)방지에 대해서 전적으로 건물의 관련 설비에 의존합니다. 보호장치의 정격이 반드시 250V(볼트), 20A(암페어)를 초과하지 않도록 해야 합니다.

Waarschuwing

Dit product is afhankelijk van de kortsluitbeveiliging (overspanning) van uw elektrische installatie. Controleer of het beveiligde apparaat niet groter gedimensioneerd is dan 220V, 20A.

Power Disconnection Warning



Warning!

The system must be disconnected from all sources of power and the power cord removed from the power supply module(s) before accessing the chassis interior to install or remove system components.

電源切断の警告 システムコンポーネントの取り付けまたは取り外しのために、シャーシ内部にアクセスするには、システムの電源はすべてのソースから切断され、電源コードは電源モジュールから取り外す必要があります。

警告

在你打 机箱并安 或移除内部器件前,必 将系 完全断 ,并移除 源 。

警告 在您打開機殼安裝或移除內部元件前，必須將系統完全斷電，並移除電源線。

Warnung

Das System muss von allen Quellen der Energie und vom Netzanschlusskabel getrennt sein, das von den Spg.Versorgungsteilmodulen entfernt wird, bevor es auf den Chassisinnenraum zurückgreift, um Systemsbestandteile anzubringen oder zu entfernen.

¡Advertencia!

El sistema debe ser disconnected de todas las fuentes de energía y del cable eléctrico quitado de los módulos de fuente de alimentación antes de tener acceso el interior del chasis para instalar o para quitar componentes de sistema.

Attention

Le système doit être débranché de toutes les sources de puissance ainsi que de son cordon d'alimentation secteur avant d'accéder à l'intérieur du châssis pour installer ou enlever des composants de système.

אזהרה! יש לנתק את המערכת מכל מקורות החשמל ויש להסיר את כבל החשמלי מהספק

לפני גישה לחלק הפנימי של המארז לצורך התקנת או הסרת רכיבים.

يجب فصل النظام من جميع مصادر الطاقة وإزانت سهك انكهرباء من وحدة امداد

انطقت قٓم انصل إلى انمناطق اندآهٓت نههٓكم تثبٓج أو إزانت مكنات الجهاز

경고!

시스템에 부품들을 장착하거나 제거하기 위해서는 쉐시 내부에 접근하기 전에 반드시 전원 공급장치로부터 연결되어있는 모든 전원과 전기코드를 분리해주어야 합니다.

Waarschuwing

Voordat u toegang neemt tot het binnenwerk van de behuizing voor het installeren of verwijderen van systeem onderdelen, dient u alle spanningsbronnen en alle stroomkabels aangesloten op de voeding (en) van de behuizing te verwijderen

Equipment Installation



Warning!

Only trained and qualified personnel should be allowed to install, replace, or service this equipment.

機器の設置 トレーニングを受け認定された人だけがこの装置の設置、交換、またはサービスを許可されています。

警告

只有过培且具有格的人才能行此的安、更和修。

警告 只有經過受訓且具資格人員才可安裝、更換與維修此設備。

Warnung

Das Installieren, Ersetzen oder Bedienen dieser Ausrüstung sollte nur geschultem, qualifiziertem Personal gestattet werden.

¡Advertencia!

Solamente el personal calificado debe instalar, reemplazar o utilizar este equipo.

אזהרה!

צוות מוסמך בלבד רשאי להתקין, להחליף את הציוד או לתת שירות עבור הציוד.

لتزكيب واستبدال أو خدمة هذا الجهاز

يجب أن يسمح فقط للموظف المؤهليه والمدريه

경고!

훈련을 받고 공인된 기술자만이 이 장비의 설치, 교체 또는 서비스를 수행할 수 있습니다.

Waarschuwing

Deze apparatuur mag alleen worden geïnstalleerd, vervangen of hersteld door geschoold en gekwalificeerd personeel.

Restricted Area



Warning!

This unit is intended for installation in restricted access areas. A restricted access area can be accessed only through the use of a special tool, lock and key, or other means of security. (This warning does not apply to workstations).

アクセス制限区域 このユニットは、アクセス制限区域に設置されることを想定しています。

アクセス制限区域は、特別なツール、鍵と錠前、その他のセキュリティの手段を用いてのみ出入りが可能です。

警告

此部件安装在限制出的所, 限制出的所指只能通过使用特殊工具、和匙或其它安全手段出的所。

警告 此装置仅限安装于进出管制区域, 进出管制区域係指仅能以特殊工具、锁头及钥匙或其他安全方式才能进入的区域。

Warnung

Diese Einheit ist zur Installation in Bereichen mit beschränktem Zutritt vorgesehen. Der Zutritt zu derartigen Bereichen ist nur mit einem Spezialwerkzeug, Schloss und Schlüssel oder einer sonstigen Sicherheitsvorkehrung möglich.

¡Advertencia!

Esta unidad ha sido diseñada para instalación en áreas de acceso restringido. Sólo puede obtenerse acceso a una de estas áreas mediante la utilización de una herramienta especial, cerradura con llave u otro medio de seguridad.

Attention

Cet appareil doit être installée dans des zones d'accès réservés. L'accès à une zone d'accès réservé n'est possible qu'en utilisant un outil spécial, un mécanisme de verrouillage et une clé, ou tout autre moyen de sécurité.

אזור עם גישה מוגבלת אזור עם גישה מוגבלת

אזהרה! יש להתקין את היחידה באזורים שיש בהם הגבלת גישה. הגישה ניתנת בעזרת

(כלי אבטחה בלבד (מפתח, מנעול וכו'

. تم تخصيص هذه انحذة تتركبها في مناطق محظورة

،مكن انصل إن منطقت محظورة فقط من خلال استخدام أداة خاصة

أو أوسهت أخري نالمالما

قفم ومفتاح

경고!

이 장치는 접근이 제한된 구역에 설치하도록 되어있습니다. 특수도구, 잠금 장치 및 키, 또는 기타 보안 수단을 통해서만 접근 제한 구역에 들어갈 수 있습니다.

Waarschuwing

Dit apparaat is bedoeld voor installatie in gebieden met een beperkte toegang. Toegang tot dergelijke gebieden kunnen alleen verkregen worden door gebruik te maken van speciaal gereedschap, slot en sleutel of andere veiligheidsmaatregelen.

Redundant Power Supplies



Warning!

This unit might have more than one power supply connection. All connections must be removed to de-energize the unit.

冗長電源装置 このユニットは複数の電源装置が接続されている場合があります。ユニットの電源を切るためには、すべての接続を取り外さなければなりません。

警告

此部件 接的 源可能不止一个, 必 将所有 源断 才能停止 部件供 。

警告 此装置連接的電源可能不只一個, 必須切斷所有電源才能停止對該裝置的供電。

Warnung

Dieses Gerät kann mehr als eine Stromzufuhr haben. Um sicherzustellen, dass der Einheit kein Strom zugeführt wird, müssen alle Verbindungen entfernt werden.

¡Advertencia!

Puede que esta unidad tenga más de una conexión para fuentes de alimentación. Para cortar por completo el suministro de energía, deben desconectarse todas las conexiones.

Attention

Cette unité peut avoir plus d'une connexion d'alimentation. Pour supprimer toute tension et tout courant électrique de l'unité, toutes les connexions d'alimentation doivent être débranchées.

אם קיים יותר מספק אחד

אם קיים יותר מספק אחד

אזהרה! ליחידה יש יותר מחיבור אחד של ספק. יש להסיר את כל החיבורים על מנת לרוקן

את היחידה.

경고!

يجب إزالة كافة الاتصالات لعسل الوحدة عن الكهرباء قد يكون لهذا الجهاز عدة اتصالات بوحدات امداد الطاقة.

이 장치에는 한 개 이상의 전원 공급 단자가 연결되어 있을 수 있습니다. 이 장치에 전원을 차단하기 위해서는 모든 연결 단자를 제거해야만 합니다.

Waarschuwing

Backplane Voltage



Warning!

Hazardous voltage or energy is present on the backplane when the system is operating. Use caution when servicing.

バックプレーンの電圧 システム稼働中は危険な電圧または電力が、バックプレーン上にかかっています。修理する際には注意ください。

警告

当系正在行时,背板上有很危险的压或能量,行修时必小心。

警告 當系統正在進行時,背板上有很危險的電壓或能量,進行維修時務必小心。

Warnung

Wenn das System in Betrieb ist, treten auf der Rückwandplatine gefährliche Spannungen oder Energien auf. Vorsicht bei der Wartung.

¡Advertencia!

Cuando el sistema está en funcionamiento, el voltaje del plano trasero es peligroso. Tenga cuidado cuando lo revise.

Attention

Lorsque le système est en fonctionnement, des tensions électriques circulent sur le fond de panier. Prendre des précautions lors de la maintenance.

מתח בפנל האחורי

מתח בפנל האחורי

אזהרה! קיימת סכנת מתח בפנל האחורי בזמן תפעול המערכת. יש להיזהר במהלך

העבודה.

خطر مه التيار الكهربي أو الطاقة المجددة على اللوحة النظام يعمل كه حذرا عند خدمة هذا الجهاز هناك عندما يكن

경고!

시스템이 동작 중일 때 후면판 (Backplane)에는 위험한 전압이나 에너지가 발생 합니다. 서비스 작업 시 주의하십시오.

Waarschuwing

Een gevaarlijke spanning of energie is aanwezig op de backplane wanneer het systeem in gebruik is. Voorzichtigheid is geboden tijdens het onderhoud.

Comply with Local and National Electrical Codes



Warning!

Installation of the equipment must comply with local and national electrical codes.

地方および国の電気規格に準拠 機器の取り付けはその地方および国の電気規格に準拠する必要があります。

警告

安 必 符合本地与本国 气法 。警告

Warnung

Die Installation der Geräte muss den Sicherheitsstandards entsprechen.

¡Advertencia!

La instalacion del equipo debe cumplir con las normas de electricidad locales y nacionales.

Attention

L'équipement doit être installé conformément aux normes électriques nationales et locales.

תיאום חוקי החשמל הארצי

תיאום חוקי החשמל הארצי

אזהרה!

התקנת הציוד חייבת להיות תואמת לחוקי החשמל המקומיים והארציים.

تركيب المعدات الكهربائية يجب أن يمثل للقوايه المحلية والبطية المتعلقة

بالكهرباء

경고!

현 지역 및 국가의 전기 규정에 따라 장비를 설치해야 합니다.

Waarschuwing

Product Disposal



Warning!

Ultimate disposal of this product should be handled according to all national laws and regulations.

製品の廃棄 この製品を廃棄処分する場合、国の関係する全ての法律・条例に従い処理する必要があります。

警告

本品的弃处理 根据所有国家的法律和 章 行。

警告 本產品的廢棄處理應根據所有國家的法律和規章進行。

Warnung

Die Entsorgung dieses Produkts sollte gemäß allen Bestimmungen und Gesetzen des Landes erfolgen.

¡Advertencia!

Al deshacerse por completo de este producto debe seguir todas las leyes y reglamentos nacionales.

Attention

La mise au rebut ou le recyclage de ce produit sont généralement soumis à des lois et/ou directives de respect de l'environnement. Renseignez-vous auprès de l'organisme compétent.

סילוק המוצר

סילוק המוצר

אזהרה!

סילוק סופי של מוצר זה חייב להיות בהתאם להנחיות וחוקי המדינה.

عند التخلص النهائي من هذا المنتج ينبغي التعامل معه وفقا لجميع القوانين واللوائح الوطنية

경고!

이 제품은 해당 국가의 관련 법규 및 규정에 따라 폐기되어야 합니다.

Power Cable and AC Adapter



Warning!

When installing the product, use the provided or designated connection cables, power cables and AC adaptors. Using any other cables and adaptors could cause a malfunction or a fire. Electrical Appliance and Material Safety Law prohibits the use of UL or CSA -certified cables (that have UL/CSA shown on the code) for any other electrical devices than products designated by Supermicro only.

電源コードとACアダプター

製品を設置する場合、提供または指定された接続ケーブル、電源コードとACアダプターを使用下さい。他のケーブルやアダプタを使用すると故障や火災の原因になることがあります。電気用品安全法は、ULまたはCSA認定のケーブル(UL/CSEマークがコードに表記)を Ivanti が指定する製品以外に使用することを禁止しています。

警告

安此品时,使用本身提供的或指定的接,源和源适配器.使用其它材或适配器可能会引起故障或火灾。除了Ivanti所指定的品,气用品和材料安全法律定禁止使用未UL或CSA的材。(材上会示UL/CSA符号)。

警告

安裝此產品時,請使用本身提供的或指定的連接線,電源線和電源適配器.使用其它線材或適配器可能會引起故障或火災。除了 Ivanti 所指定的產品,電氣用品和材料安全法律規定禁止使用未經 UL或CSA認證的線材。(線材上會顯示UL/CSA符號)。

Warnung

Bei der Installation des Produkts, die zur Verfügung gestellten oder benannt Anschlusskabel, Stromkabel und Netzteile. Verwendung anderer Kabel und Adapter kann zu einer Fehlfunktion oder ein Brand entstehen. Elektrische Geräte und Material Safety Law verbietet die Verwendung von UL-oder CSA-zertifizierte Kabel, UL oder CSA auf der Code für alle anderen elektrischen Geräte als Produkte von Ivanti nur bezeichnet gezeigt haben.

¡Advertencia!

Al instalar el producto, utilice los cables de conexión previstos o designados, los cables y adaptadores de CA. La utilización de otros cables y adaptadores podría ocasionar un mal funcionamiento o un incendio. Aparatos Eléctricos y la Ley de Seguridad del Material prohíbe el uso de UL o CSA cables certificados que tienen UL o CSA se muestra en el código de otros dispositivos eléctricos que los productos designados por Ivanti solamente.

Attention

Lors de l'installation du produit, utilisez les bables de connection fournis ou désigné. L'utilisation d'autres cables et adaptateurs peut provoquer un dysfonctionnement ou un incendie. Appareils électroménagers et de loi sur la sécurité Matériel interdit l'utilisation de UL ou CSA câbles certifiés qui ont UL ou CSA indiqué sur le code pour tous les autres appareils électriques que les produits désignés par Ivanti seulement.

חשמליים ומתאמי

AC חשמליים ומתאמי

אזהרה!

אשר לשם כך. שימוש בכל כבל או מתאם AC מתקינים את המוצר, יש להשתמש בכבלים, ספקים ומתאמים אחר יכול לגרום לתקלה או כאשר על פי חוקי שימוש במכשירי חשמל וחוקי בטיחות, קיים איסור נועדו וסופקו קצר חשמלי.

כשאר מופיע עליהם קוד של)

CSA- או ב UL-להשתמש בכבלים המוסמכים ב

עבור כל מוצר חשמלי אחר שלא צוין על ידי סופרמיקרו בלבד UL/CSA)

عند تركيب الجهاز يجب استخدام كابلات التوصيل، والكابلات الكهربائية
ومحولات التيار المتردد
التي . أن استخدام أي كابلات ومحولات أخرى يتسبب في حدوث عطل أو حريق.
تم توفيرها لك مع المنتج
الأجهزة الكهربائية ومواد قانون السلامة يحظر استخدام الكابلات CSA أو UL
معتمدة من قبل
لأي أجهزة كهربائية أخرى غير المنتجات المعينة من قبل Supermicro
(التي تحمل علامة UL/CSA)

Ivanti

경고!

제품을 설치할 때에는 제공되거나 지정된 연결케이블과 전원케이블, AC어댑터를 사용해야 합니다. 그 밖의 다른 케이블들이나 어댑터들은 고장 또는 화재의 원인이 될 수 있습니다. 전기용품안전법 (Electrical Appliance and Material Safety Law)은 슈퍼마이크로에서 지정한 제품들 외에는 그 밖의 다른 전기 장치들을 위한 UL또는 CSA에서 인증한 케이블(전선 위에 UL/CSA가 표시) 들의 사용을 금지합니다.

Waarschuwing

Bij het installeren van het product, gebruik de meegeleverde of aangewezen kabels, stroomkabels en adapters. Het gebruik van andere kabels en adapters kan leiden tot een storing of een brand. Elektrisch apparaat en veiligheidsinformatiebladen wet verbiedt het gebruik van UL of CSA gecertificeerde kabels die UL of CSA die op de code voor andere elektrische apparaten dan de producten die door Ivanti alleen.

Certification Statements

China



关于符合中国《电器电子产品有害物质限制使用管理办法》的声明
Management Methods for the Restriction of the Use of Hazardous Substances from Electrical and Electronic Products
(China RoHS Declaration)

产品中有害物质的名称及含量 (Name and Concentration of Toxic Substances)

产品型号(Super Micro Part Number): ISA8000, ISA8000C, ISA8000F 日期(Date): 05/31/2023

部件名称 (Parts)	有毒有害物质或元素 (Toxic substances or elements)					
	铅 (Pb)	汞 (Hg)	镉 (Cd)	六价铬 (Cr6+)	多溴联苯 (PBB)	多溴二苯醚 (PBDE)
机壳 (Chassis)	O	O	O	O	O	O
线材(Cable)	O	O	O	O	O	O
风扇(Fan)	X	O	O	O	O	O
硬盘(Hard Drive)	X	O	O	O	O	O
主板(Motherboard)	X	O	O	O	O	O
附加卡(Add-on Card)	X	O	O	O	O	O
电源背板 (Backplane)	X	O	O	O	O	O
机内电源单元 (Power Supply)	X	O	O	O	O	O

本表格依据 SJ/T 11364 的规定编制。(This table is based on SJ/T 11364.)
O: 表示该有害物质在该部件所有均质材料中的含量均在 GB/T 26572 规定的限量要求以下。
(Indicates that this toxic or hazardous substances contained in all of the homogeneous materials for this part is below the limit requirement specified in GB/T 26572.)
X: 表示该有害物质至少在该部件的某一均质材料中的含量超出 GB/T 26572 规定的限量要求, 但所有部件都符合欧盟 RoHS 要求。
(Indicates that this toxic or hazardous substances contained in at least one of the homogeneous materials used for this part is above the limit requirement specified in GB/T 26572. All parts comply with EU RoHS Directive.)
(注意: 在此处, 根据具体情况对上表中打“X”的技术原因进行进一步说明。)(According to the "X" in this Table, Please note the Technical reasons or Instructions here.)



此环保使用期限只适用于产品是在产品手册中所规定的条件下工作。产品部件本体上如有环保使用期限标识, 以部件本体标识为主。(Environmental Friendly Use Period (EFUP) for the product is per the symbol shown here and is only valid when the product is performed under the conditions defined in the product manual.)

ivanti.com | 10377 South Jordan Gateway, Suite 110, South Jordan, Utah 84095 | +1 888 253 6201

Japan

この装置は、クラスA 情報技術装置です。この装置を家庭環境で使用すると電波妨害を引き起こすことがあります。この場合には使用者が適切な対策を講ずるよう要求されることがあります。VCCI-A

Israel

ת בתדר רדיו, ובמקרה זה, המשתמש עשוי להידרש

Saudi Arabia

Complies with the CITC Technical Specification CITC GEN001, IT001.

South Korea

이 기기는 업무용(A급) 전자파 적합기기로서 판매자 또는 사용자는 이 점을 주의하시기 바라며, 가정외의 지역에서 사용하는 것을 목적으로 합니다.

Taiwan

警告使用者：這是甲類的資訊產品，在居住的環境中使用時，可能會造成射頻干擾，在這種情況下，使用者會被要求採取某些適當的對策

Thailand

เครื่องโทรคมนาคม และอุปกรณ์นี้ มี ความสอดคล้อง อดตามข้อ อกำ หนดของ กสทช.



Restriction of Hazardous Substances

Restricted substances:

- Lead (0,1 %)
- Mercury (0,1 %)
- Cadmium (0,01 %)
- Hexavalent chromium (0,1 %)
- Polybrominated biphenyls (PBB) (0,1 %)
- Polybrominated diphenyl ethers (PBDE) (0,1 %)
- Bis(2-ethylhexyl) phthalate (DEHP) (0,1 %)
- Butyl benzyl phthalate (BBP) (0,1 %)
- Dibutyl phthalate (DBP) (0,1 %)
- Diisobutyl phthalate (DIBP) (0,1 %)

RoHS Declaration

Supermicro certifies that to the best of our knowledge and belief, all parts listed in this document meet the requirement of the **European Parliament 2011/65/EU and Delegated Directive (EU) 2015/863**, on the restriction of the use of certain hazardous substances in the electrical and electronic equipment with the exemptions listed below. Supermicro bases its knowledge from information obtained by third parties and/or its suppliers. Supermicro makes no representation as to the accuracy of the information and disclaims liabilities with respect to the information.

Exemptions:

- 6(a)-I – Lead as an alloying element in steel for machining purposes containing up to 0.35% lead by weight and in batch hot dip galvanized steel components containing up to 0.2% lead by weight
- 6(b)-I – Lead as an alloying element in aluminum containing up to 0.4% lead by weight, provided it stems from lead-bearing aluminum scrap recycling
- 6(b)-II – Lead as an alloying element in aluminum for machining purposes with a lead content of up to 0.4% lead by weight
- 6(c) – Copper alloy containing up to 4% lead by weight
- 7(a) – Lead in high melting temperature type solders (i.e. lead-based alloys containing 85% by weight or more lead)
- 7(c)-I – Electrical and electronic components containing lead in a glass or ceramic other than dielectric ceramic in capacitors, e.g. piezoelectric devices, or in a glass or ceramic matrix compound
- 7(c)-II – Lead in dielectric ceramic in capacitors for a rated voltage of 125 V AC or 250 V DC or higher.
- 7(c)-IV – Lead in PZT based dielectric ceramic materials for capacitors which are part of integrated circuits or discrete semiconductors.
- 8(b) (I) – Cadmium and its compounds in electrical contacts (see RoHS regulation for current exempted applications)
- 15(a) – Lead in solders to complete a viable electrical connection between the semiconductor die and carrier within integrated circuit flip chip packages where at least one criteria applies (see RoHS regulation for current criteria)
- Compliant- Uses no exemptions

Super Micro Part Number: ISA8000

Date: 2023/06/01

Signature:

Name: Tina Chen
Title: Sr. Compliance Engineer

Super Micro Computer Inc.

980 Rock Ave, San Jose, CA 95131

Revised 03/16/20



限用物質含有情況標示聲明書

Declaration of the Presence Condition of the Restricted Substances Marking

設備名稱: Ivanti 安全設備 (Ivanti Security Appliance) Equipment name						
型號 (型式) : ISA8000, ISA8000C, ISA8000F Type designation (Type)						
單元 Unit	限用物質及其化學符號 Restricted substances and its chemical symbols					
	鉛Lead (Pb)	汞Mercury (Hg)	鎘Cadmium (Cd)	六價鉻Hexavalent chromium (Cr ⁶⁺)	多溴聯苯Polybrominated biphenyls (PBB)	多溴二苯醚Polybrominated diphenyl ethers (PBDE)
機殼 (Chassis)	○	○	○	○	○	○
機殼風扇 (Chassis Fan)	-	○	○	○	○	○
線材 (Cable)	○	○	○	○	○	○
主機板 (Motherboard)	-	○	○	○	○	○
電源供應器 (Power Supply)	-	○	○	○	○	○
電源背板 (PDB)	-	○	○	○	○	○
硬碟 (HDD)	-	○	○	○	○	○
附加卡 (Add-on card)	-	○	○	○	○	○
<p>備考1. “超出0.1 wt %”及“超出0.01 wt %”係指限用物質之百分比含量超出百分比含量基準值。 Note 1 : “Exceeding 0.1 wt %” and “exceeding 0.01 wt %” indicate that the percentage content of the restricted substance exceeds the reference percentage value of presence condition.</p> <p>備考2. “○”係指該項限用物質之百分比含量未超出百分比含量基準值。 Note 2 : “○” indicates that the percentage content of the restricted substance does not exceed the percentage of reference value of presence.</p> <p>備考3. “-”係指該項限用物質為排除項目。 Note 3 : The “-” indicates that the restricted substance corresponds to the exemption.</p>						